

Linea™ HS

4k, 8k, 13k and 16k Monochrome / HDR CMOS TDI Cameras

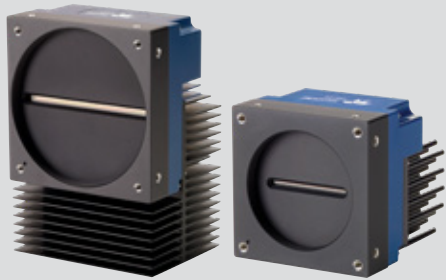

Key Features

- » High speed up to 400 kHz
- » High sensitivity
- » High dynamic range (HDR)
- » Up to 100 m optical cable length

Programmability

- » Multiple regions and areas of interest
- » 8 or 12 bit output
- » Flat field and lens shading correction
- » Programmable coefficient sets
- » GenICam™ compliant interfacing
- » Rapid coefficient changes

Typical Applications

- » Flat panel inspection
- » Gene sequencing
- » Digital pathology
- » Printed circuit board inspection
- » Web Inspection
- » Machine vision

Advanced High-Speed, High-Sensitivity TDI Camera

Based on Teledyne DALSA's industry leading CMOS TDI technology, the award-winning Linea HS™ cameras are the most advanced TDI products in the marketplace. These cameras deliver the highest performance with unique features that significantly improve detectability for many demanding applications. The cameras come with the next-generation CLHS interface, delivering up to 8.4 Gigapixels per second over a single fiberoptic cable.

Specifications	
Resolution	4,094 x 192 pixels (4k); 8,192 x 192 pixels (8k) 13,056 x 192 pixels (13k); 16,384 x 192 pixels (16k)
Line Rate	400 kHz maximum
Pixel Size	5 x 5 µm
Data Format	8 or 12 bits, selectable
Output	Monochrome / HDR
Lens Mount	M58 x 0.75 (4k, 8k) M90 x 1 (13k, 16k)
Responsivity	See graph
Dynamic Range	70 dB
Nominal Gain Range	1x to 10x
Size	76 mm x 76 mm x 85 mm (4k, 8k) 97 mm x 140.5 mm x 78.6 mm (13k, 16k)
Mass	500 g (4k, 8k) 1.2 kg (13k, 16k)
Operating Temp	0 °C to +65 °C, front plate
Power	+12 V to +24 V DC, Hirose 12-pin
Power Dissipation	<18 W (4k, 8k) <30 W (13k, 16k)
Control & Data	Camera Link HS, CX4/LC
GPIO	Direction and independent line control
Regulatory Compliance	CE, FCC, and RoHS

Camera Model

Part Number	Resolution	Max. Line Rates	Pixel Size	Output
HL-FM-04K30H-00-R	4,096 x (128+64)	300 kHz	5 µm x 5 µm	Mono/HDR
HL-FM-08K30H-00-R	8,192 x (128+64)	280 kHz	5 µm x 5 µm	Mono/HDR
HL-HM-08K30H-00-R	8,192 x (128+64)	300 kHz	5 µm x 5 µm	Mono/HDR
HL-HM-08K40H-00-R	8,192 x (128+64)	400 kHz	5 µm x 5 µm	Mono/HDR
HL-FM-13K18H-00-R	13,056 x (128+64)	180 kHz	5 µm x 5 µm	Mono/HDR
HL-HM-13K30H-00-R	13,056 x (128+64)	300 kHz	5 µm x 5 µm	Mono/HDR
HL-FM-16K15A-00-R	16,384 x 128	140 kHz	5 µm x 5 µm	Mono
HL-HM-16K30H-00-R	16,384 x (128+64)	300 kHz	5 µm x 5 µm	Mono/HDR
HL-HM-16K40H-00-R	16,384 x (128+64)	400 kHz	5 µm x 5 µm	Mono/HDR

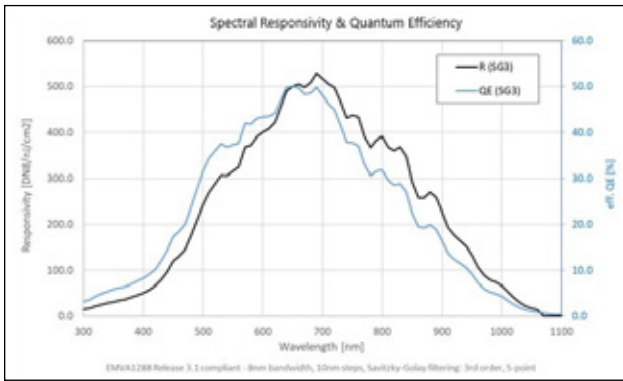

4k, 8k Model

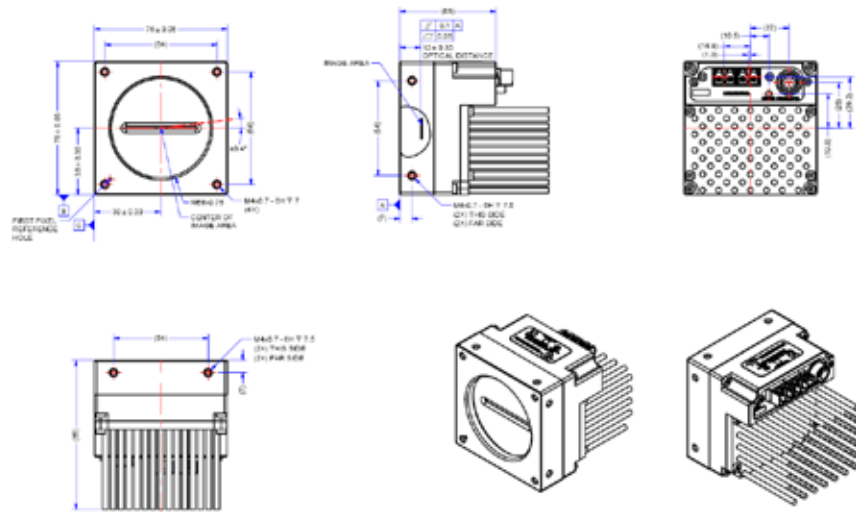

NOTES:
1. UNITS: MILLIMETERS
2. BRACKET AREA IS REFERRED TO DATUMS

13k, 16k Model

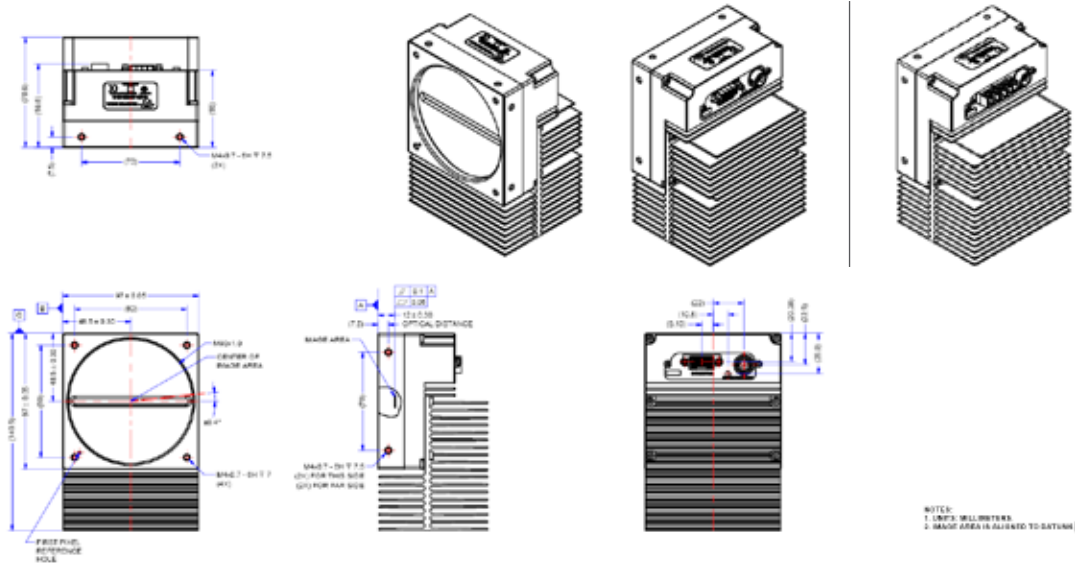

NOTES:
1. UNITS: MILLIMETERS
2. BRACKET AREA IS REFERRED TO DATUMS

Americas
Boston, USA
+1 978-670-2000
sales.americas@teledynedalsa.com

Europe
Krailing, Germany
+49 89-89-54-57-3-80
sales.europe@teledynedalsa.com

Asia Pacific
Tokyo, Japan
+81 3-5960-6353
sales.asia@teledynedalsa.com

Shanghai, China
+86 21-3368-0027
sales.asia@teledynedalsa.com

Linea™ HS Color

16k Multi-Array CMOS TDI Camera

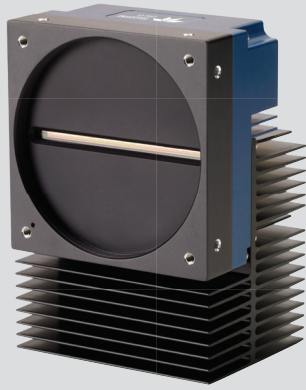

Key Features

- » High speed 100 kHz x 3
- » High sensitivity multi-array TDI
- » Capture three native colors
- » Bi-directionality
- » Next gen Camera Link HS interface

Programmability

- » Multiple Regions of Interest for calibration, data reduction
- » 8 or 12 bit output
- » Flat field and lens shading correction
- » Programmable coefficient sets

Typical Applications

- » Flat panel display inspection
- » Printed circuit board inspection
- » Semiconductor wafer
- » Life sciences
- » Web inspection
- » General purpose machine vision

High Speed and High Sensitivity Color TDI Camera

Based on Teledyne DALSA's industry leading CMOS TDI technology, the new Linea HS color camera offers the most advanced performance for color imaging in the marketplace. This camera delivers the highest speeds and highest sensitivity for many demanding color applications. The camera comes with the next-generation CLHS interface, delivering up to 8.4 Gigapixels per second over a single active optical cable.

Specifications	
Resolution	16,384 x (64+128+64) pixels
Line Rate	100 kHz x 3
Pixel Size	5 x 5 μm
Bit Depth	8 or 12 bit selectable
Lens Mount	M90 x 1
Responsivity	See graph
Dynamic Range	69 dB
Nominal Gain Range	1x ~10x
Size	97 mm x 140.5 mm x 78.6 mm
Mass	1200 g
Operating Temp	0° C to +60° C, front plate
Power Supply	+12 to +24 VDC
Power Dissipation	30 W
Data & Control	Camera Link HS, CX4
GPIO	Hironse 12-pin
Regulatory Compliance	CE, FCC, and RoHS

Camera Model

Part Number	Resolution	Max. Line Rate	Pixel Size	Output
HL-HC-16k10T	16,384 x (64+128+64) pixels	100 kHz x 3	5 x 5 μm	RGB

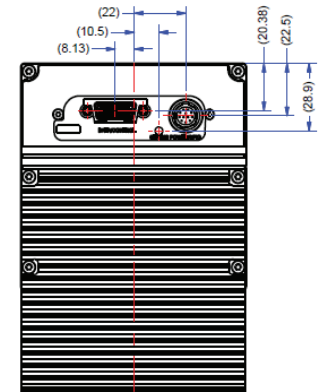
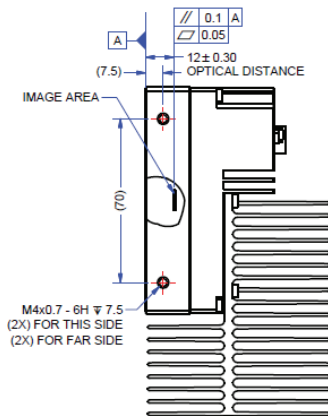
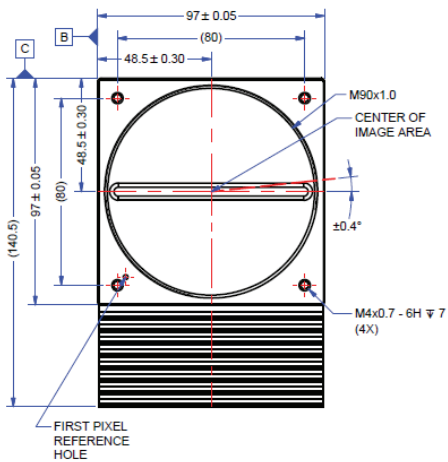
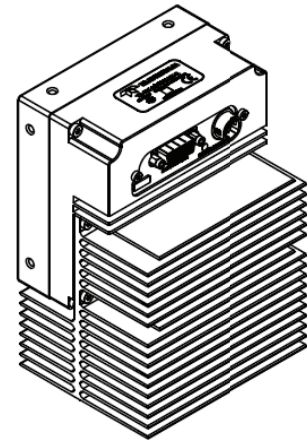
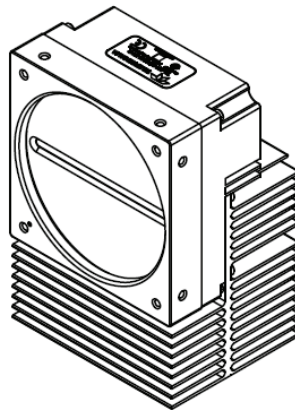
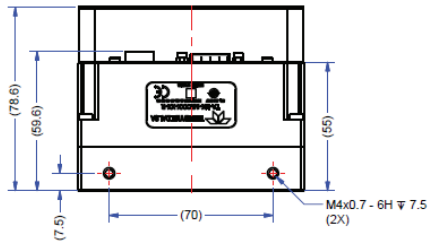
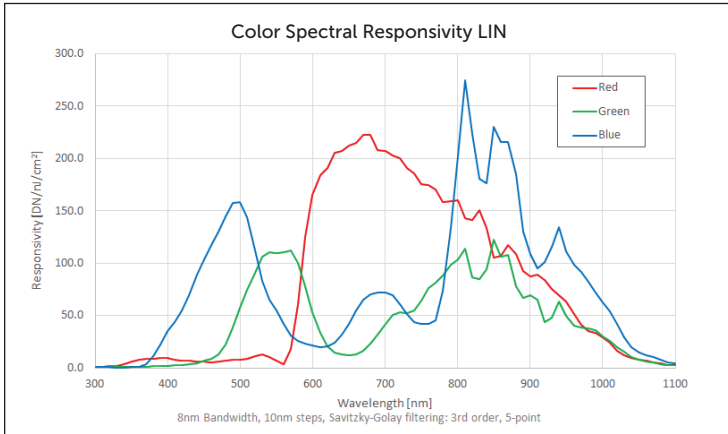

NOTES:
1. UNITS: MILLIMETERS.
2. IMAGE AREA IS ALIGNED TO DATUMS A B & C.

Americas

Boston, USA
+1 978-670-2000
sales.americas@teledynedalsa.com

Europe

Krailling, Germany
+49 89-89-54-57-3-80
sales.europe@teledynedalsa.com

Asia Pacific

Tokyo, Japan
+81 3-5960-6353
sales.asia@teledynedalsa.com

Shanghai, China
+86 21-3368-0027
sales.asia@teledynedalsa.com

Linea™ HS

32k CMOS TDI Camera

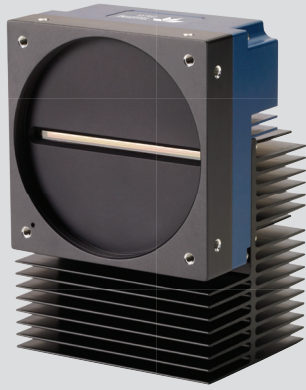

Key Features

- » 32k super resolution
- » High speed 400 kHz
- » High sensitivity TDI
- » Bi-directionality
- » Assisted alignment marks

Programmability

- » Multiple Regions of Interest for calibration, data reduction
- » 8 bit output
- » Flat field and lens shading correction
- » Programmable coefficient sets

Typical Applications

- » Flat panel display inspection
- » Printed circuit board inspection
- » Semiconductor wafer
- » Life sciences
- » Web inspection
- » General purpose machine vision

Industry's First 32k TDI Camera with Improved Detectability

Based on Teledyne DALSA's industry leading CMOS TDI technology, the new Linea HS family offers advanced and unique TDI products. The Linea HS 32k camera is capable of capturing 32,768 pixel data using patent-pending pixel offset technology. This enables users to significantly improve subpixel defect detectability while using existing optical lenses and maintaining high sensitivity. The camera comes with high-speed fiber optic interface that delivers up to 8.4 GByte/sec data in a single cable and long cable length.

Patent Pending Pixel Offset Technology

The 32k camera uses two 16k/5 μm TDI arrays with ½ pixel offset. Two 16k/5 μm image data are captured and then reconstructed to achieve a super resolution image of 32k/2.5 μm in real time. This significantly enhances detectability for subpixel defects. One advantage of the pixel offset technology is that existing 16k/5 μm lenses can be used without sacrifice in responsivity and MTF with a smaller physical pixel size.

Specifications

Resolution	32,768 x 64 pixels
Line rate	400 kHz maximum*
Pixel Size	5 x 5 μm / 2.5 x 2.5 μm
Bit depth	8 bit
Output	Monochrome
Lens Mounts	M90 x 1
Responsivity	see graph
Nominal Gain Range	1x to 10x
Size	97 x 140.5 x 78.6 mm
Mass	1200 g
Operating Temp	0 to +60 °C (frontplate)
Power Supply	+12 to +24 VDC
Power Dissipation	28 W
Data and Control	Camera Link HS CX4
GPIO	Hirose 12-pin
Regulatory Compliance	CE, FCC, RoHS

* Due to bandwidth limitation of the FG, max. line rate can be achieved with 2x FGs.

Camera Models

Part Number	Resolution	Max. Line Rate	Pixel Size	Output
HL-HM-32k40S-00-R	32,768 x 64 pixels	400 kHz*	5 x 5 μm 2.5 x 2.5 μm	Mono

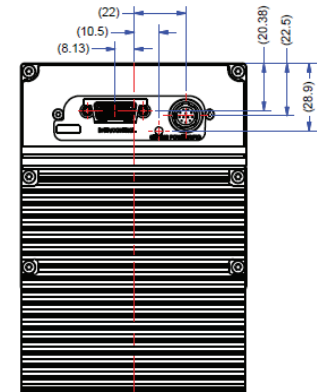
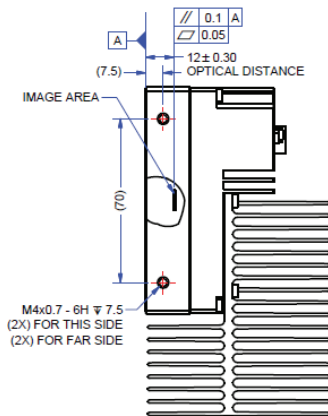
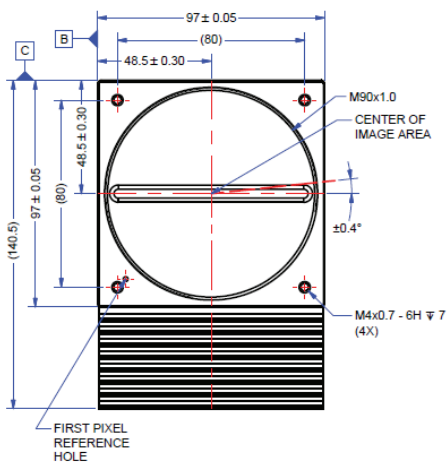
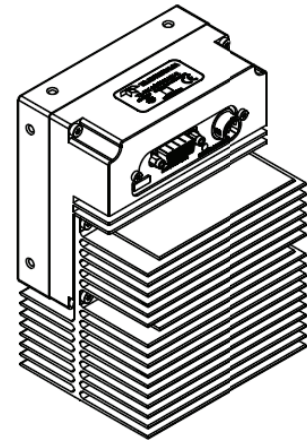
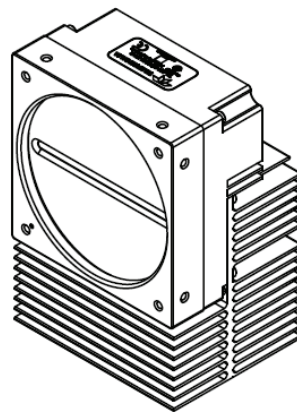
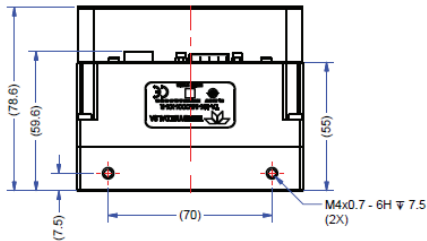
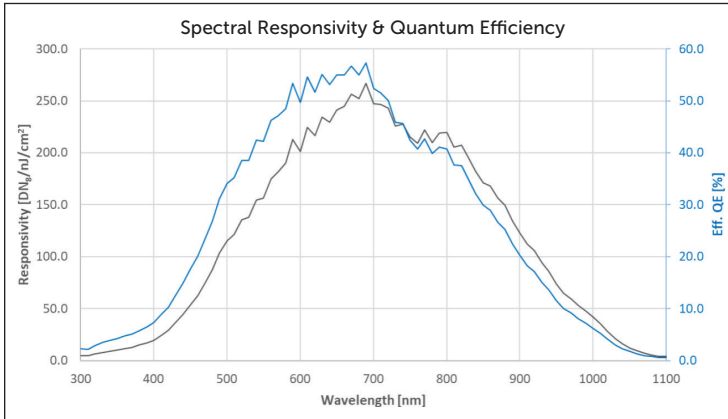

NOTES:
1. UNITS: MILLIMETERS.
2. IMAGE AREA IS ALIGNED TO DATUMS **A** **B** & **C**.

Americas

Boston, USA
+1 978-670-2000
sales.americas@teledynedalsa.com

Europe

Krailling, Germany
+49 89-89-54-57-3-80
sales.europe@teledynedalsa.com

Asia Pacific

Tokyo, Japan
+81 3-5960-6353
sales.asia@teledynedalsa.com

Shanghai, China
+86 21-3368-0027
sales.asia@teledynedalsa.com

Linea™ HS Multifield

16k Multi-array CMOS TDI Camera

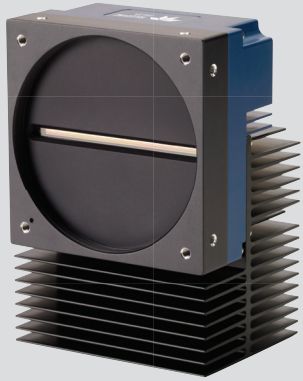

Key Features

- » Capture three field images simultaneously in a single scan
- » High speed 133 kHz x 3
- » High sensitivity multi-array TDI
- » Bi-directionality
- » Assisted alignment marks

Programmability

- » Multiple Regions of Interest for calibration, data reduction
- » 8 or 12 bit output
- » Flat field and lens shading correction
- » Programmable coefficient sets

Typical Applications

- » Flat panel display inspection
- » Printed circuit board inspection
- » Semiconductor wafer
- » Life sciences
- » Web inspection
- » General purpose machine vision

Industry's First Multifield TDI Camera with High Throughput and Detectability

Based on Teledyne DALSA's industry leading CMOS TDI technology, the new Linea HS Multifield™ camera is the most advanced TDI product in the marketplace. This camera delivers the highest performance available, with unique features that significantly improve detectability for many demanding applications. The camera comes with high-speed fiber optic interface, delivering up to 8.4 Gigapixels per second over a single and long length fiber optic cable.

Multifield Technology

Multifield is a new imaging technology that enables capturing multiple images simultaneously using various lighting conditions (e.g. brightfield, darkfield, and backlight) in a single scan.

Teledyne DALSA's Linea HS Multifield camera is the first in the industry capable of capturing up to three images using light sources at different wavelengths. The camera uses advanced wafer-level coated dichroic filters with minimum spectral crosstalk to spectrally isolate three images captured by separate TDI arrays. It can be used for color imaging as well.

This new technology significantly improves inspection speeds and image quality, as it eliminates the need for multiple scans. The difference between traditional color imaging and multifield imaging is the filter technology. Conventional color filters have significant spectral crosstalk between RGB channels, while the multifield filters have minimum spectral crosstalk.

Specifications

Resolution	16,384 x 256 pixels
Line rate	133 kHz x 3
Pixel Size	5 x 5 μm
Bit depth	8 or 12 bit selectable
Lens Mounts	M90 x 1
Responsivity	See graph
Dynamic Range	69 dB
Nominal Gain Range	1x to 10x
Size	97 x 140.5 x 78.6 mm
Mass	1200 g
Operating Temp	0 to +60 °C (front plate)
Power Supply	+12 to +24 VDC
Power Dissipation	28 W
Data and Control	Camera Link HS CX4
GPIO	Hirose 12-pin
Regulatory Compliance	CE, FCC, RoHS

Camera Models

Part Number	Resolution	Max. Line Rate	Pixel Size	Output
HL-HF-16K13T-00-R	16,384 x (64 +128 + 64)	133 kHz x 3	5 x 5 μm	F1, F2, F3

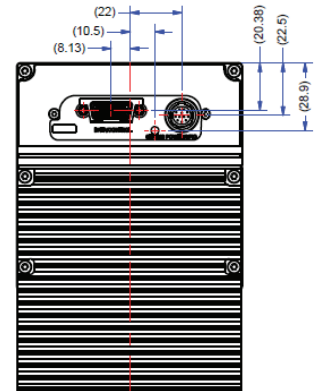
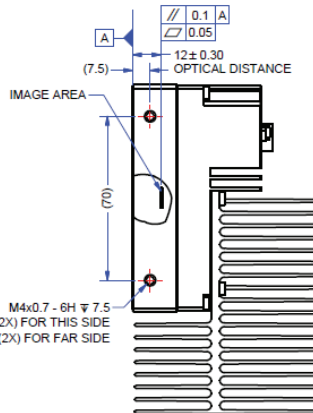
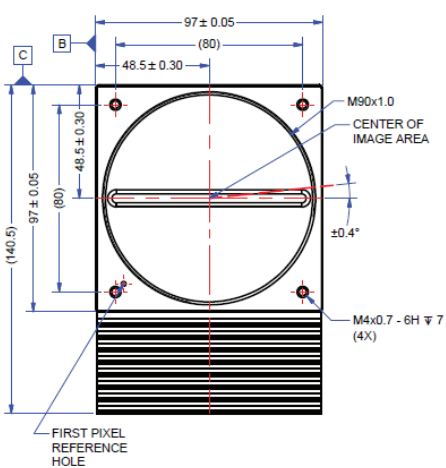
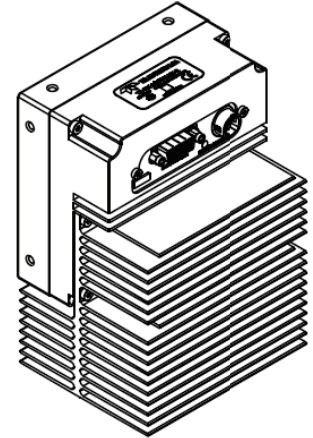
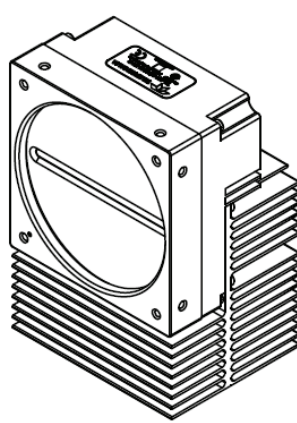
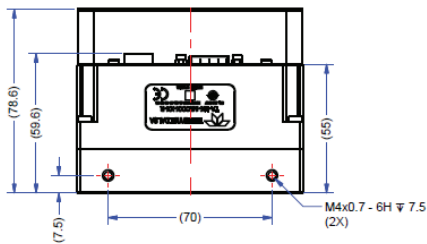
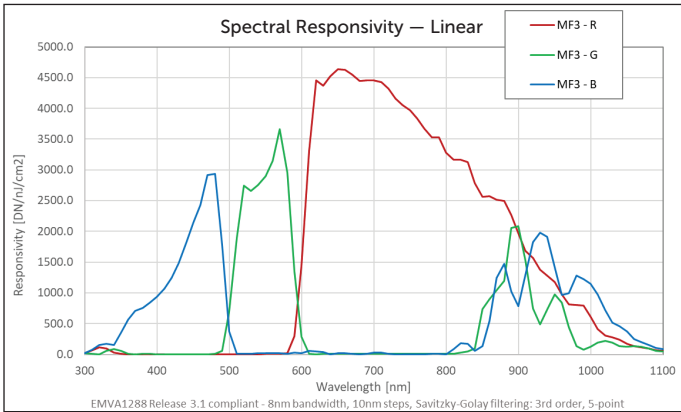

NOTES:
 1. UNITS: MILLIMETERS.
 2. IMAGE AREA IS ALIGNED TO DATUMS **A**, **B** & **C**.

Americas

Boston, USA
 +1 978-670-2000
 sales.americas@teledynedalsa.com

Europe

Krailling, Germany
 +49 89-89-54-57-3-80
 sales.europe@teledynedalsa.com

Asia Pacific

Tokyo, Japan
 +81 3-5960-6353
 sales.asia@teledynedalsa.com

Shanghai, China
 +86 21-3368-0027
 sales.asia@teledynedalsa.com

LINEA™ HS BSI

BSI TDI NUV/visible Camera



KEY FEATURES

- Backside illumination
- High resolution and High-speed
- High-sensitivity for UV imaging
- Programmable coefficient sets
- Flat field and lens shading correction
- Long optical cable length

TYPICAL APPLICATIONS

- Flat panel inspection
- Wafer inspection
- PCB and electronics
- Gene sequencing
- Digital pathology
- Fluorescence imaging
- General machine vision

High-Speed and High-Sensitivity BSI TDI

Based on Teledyne DALSA's industry leading CMOS TDI technology, the award-winning Linea HS™ cameras are the most advanced TDI products in the marketplace. These backside illumination cameras significantly enhances the sensitivity in particular for UV imaging. The cameras come with the next-generation CLHS interface, delivering up to 6.5 Gigapixels per second over a single active optical cable.

SPECIFICATIONS

HL-HM-16k40H-00-B	
Resolution (pixels)	16,384 x (128+64)
Line Rate (kHz)	400/200
Pixel Size (µm)	5 x 5
Output	Mono/HDR
Data Format (bit)	8 or 12
Dynamic Range (dB)	67
Full Well (ke-)	27
Read Noise (e-)	14
Power Dissipation (W)	30
Operating Temp (°C)	0 to +65 front plate
Dimension (mm)	97 (W) x 140.5 (H) x 78.6 (D)
Weight (g)	1200
Lens Mount	M90 x 1
Data Interface	CLHS CX4
Power and GPIO	+12 to +24VDC, Hirose 12-pin

SPECIFICATIONS

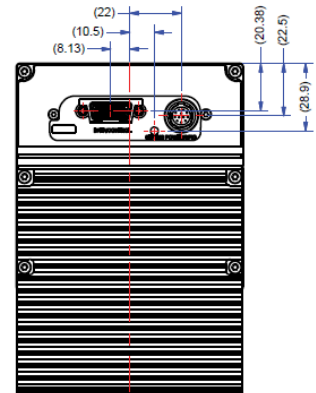
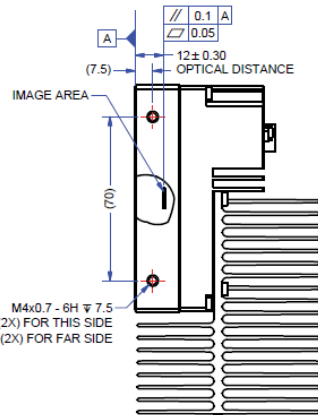
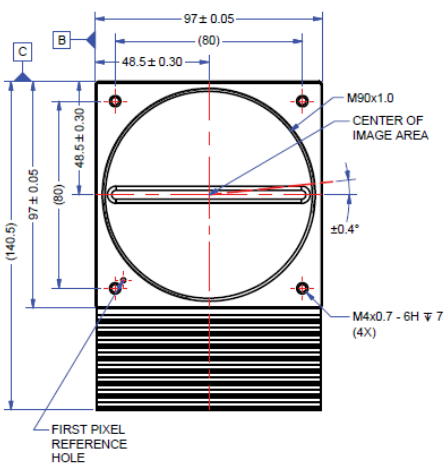
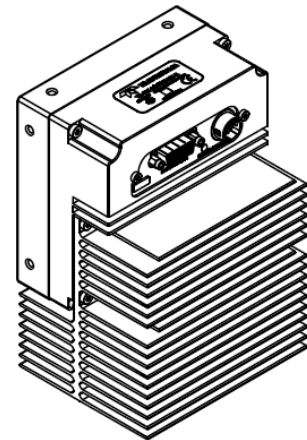
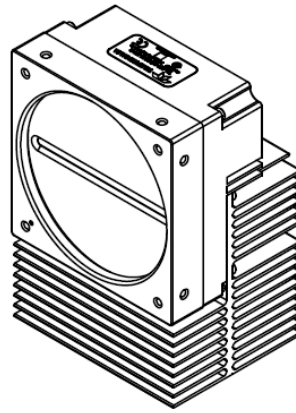
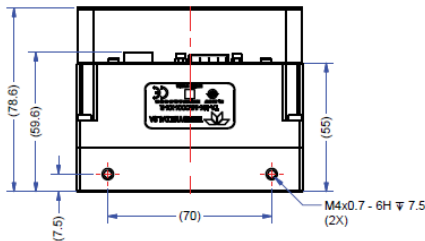
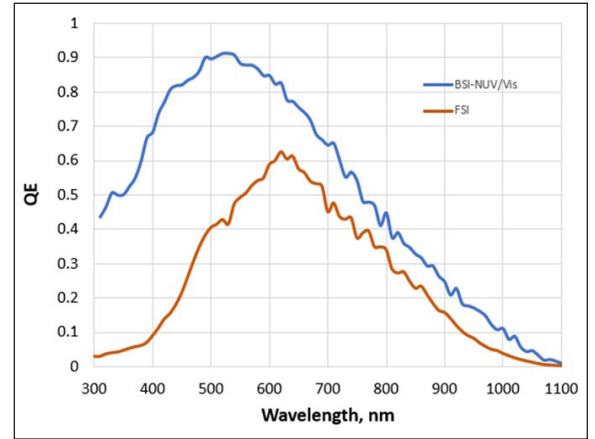
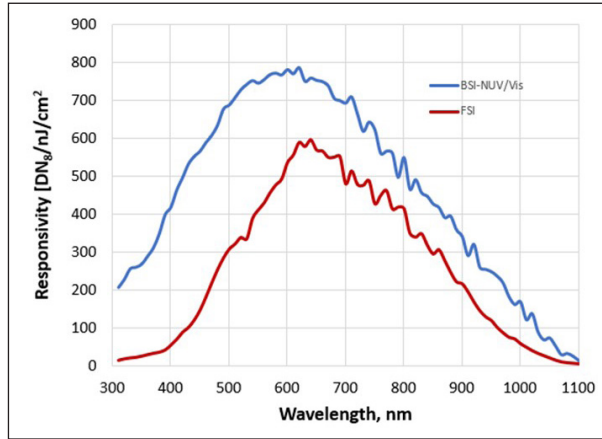

NOTES:
1. UNITS: MILLIMETERS.
2. IMAGE AREA IS ALIGNED TO DATUMS **A**, **B** & **C**.

FOR MORE INFORMATION CONTACT:

AMERICAS Boston, USA | +1 978-670-2000 | TDI_sales.americas@teledynedalsa.com
 EUROPE Krailling, Germany | +49 89-89-54-57-3-80 | TDI_sales.europe@teledynedalsa.com
 ASIA PACIFIC Tokyo, Japan | +81 3-5960-6353 | TDI_sales.asia@teledynedalsa.com
 Shanghai, China | +86 21-3368-0027 | TDI_sales.asia@teledynedalsa.com

This document does not contain information whose export/transfer/disclosure is restricted by the Canadian Export Control regulation. Teledyne DALSA has its corporate offices in Waterloo, Canada. Teledyne DALSA reserves the right to make changes at any time without notice. © Teledyne DALSA.

Document Number: 03-070-25003
Revision Date: 2023 05 01